

SVS CEILING LIFTS

For large & heavy projectors

SVS 7HSE Series

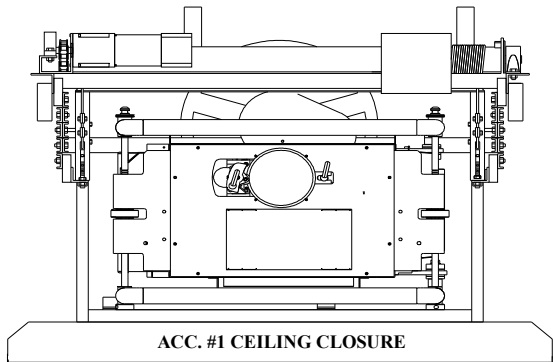

PRODUCT FEATURES

- For "large projectors" requiring additional size and weight accommodations
- Lowering distances from 9' to 22'6" [2.7m to 6.9m]
- Lifting capacity up to 900 lbs [408 kg]
- Three positions: Stored, Show (adjustable) & Service
- Supplied with 24VAC wall plate controller for low voltage control, a removable #13 platform (to support the projector in an upright position) and one Accessory #7 video cable retractor (7HSE-9/7HSE-13), two Accessories #7 video cable retractors (7HSE-15/7HSE-22).
- Very quiet operation
- Warranty: 5 Year parts, 1 year motor & 90 day factory labor

SPECIFICATIONS

LIFT MODEL	MAXIMUM LOWERING DISTANCE	VERTICAL HEIGHT OF LIFT IN CLOSED POSITION	PHYSICAL DIMENSIONS		NET WEIGHT	ESTIMATED SHIPPING WEIGHT
			WIDTH	DEPTH		
7HSE-9	9'0" / 2.7m	HEIGHT VARIES WITH PROJECTOR	43.25" / 1098mm	68" / 1727mm	320 lbs / 145.1 kg	455 lbs / 206.3 kg
7HSE-11	11'3" / 3.4m		43.25" / 1098mm	68" / 1727mm	335 lbs / 151.9 kg	490 lbs / 222.2 kg
7HSE-13	13'6" / 4.1m		43.25" / 1098mm	68" / 1727mm	350 lbs / 158.7 kg	500 lbs / 226.7 kg
7HSE-15*	15'9" / 4.8m		43.5" / 1104mm	68" / 1727mm	365 lbs / 165.5 kg	575 lbs / 260.8 kg
7HSE-18*	18'0" / 5.5m		43.5" / 1104mm	68" / 1727mm	390 lbs / 176.9 kg	605 lbs / 274.4 kg
7HSE-20*	20'3" / 6.2m		43.5" / 1104mm	68" / 1727mm	405 lbs / 183.7 kg	630 lbs / 285.7 kg
7HSE-22*	22'6" / 6.9m		43.5" / 1104mm	68" / 1727mm	420 lbs / 190.5 kg	665 lbs / 301.6 kg

* Dual Cable retractor & Heavy duty motor included (7HSE-9, 7HSE-11, 7HSE-13 feature one Accessory #7 video cable retractor)

STANDARD SPECIFICATIONS

Voltage	110v/220V, 60/50hz
Current Draw	1.5 amps [110v], .75 amps [220v]
Control Voltage	24 VAC (contact closure)
Materials	Steel/Aluminum/Nylon

RECOMMENDED ACCESSORIES

#1 Ceiling Closure – Self-aligning closure system complete with ceiling framework. Supplied with 15/16" ceiling trim ring. Designed to accept ceiling tile or dry wall ceiling. Supplied unpainted.

FP1 Ceiling Closure – Fixed mounted flat closure panel- Lipped or Lipless. Supplied with 15/16" ceiling trim ring. Ceiling material attaches to the bottom of the panel or closure can be painted. Supplied unpainted.

#2 Plenum Shroud – Metal cover to protect lift and projector in air plenum rated ceiling.

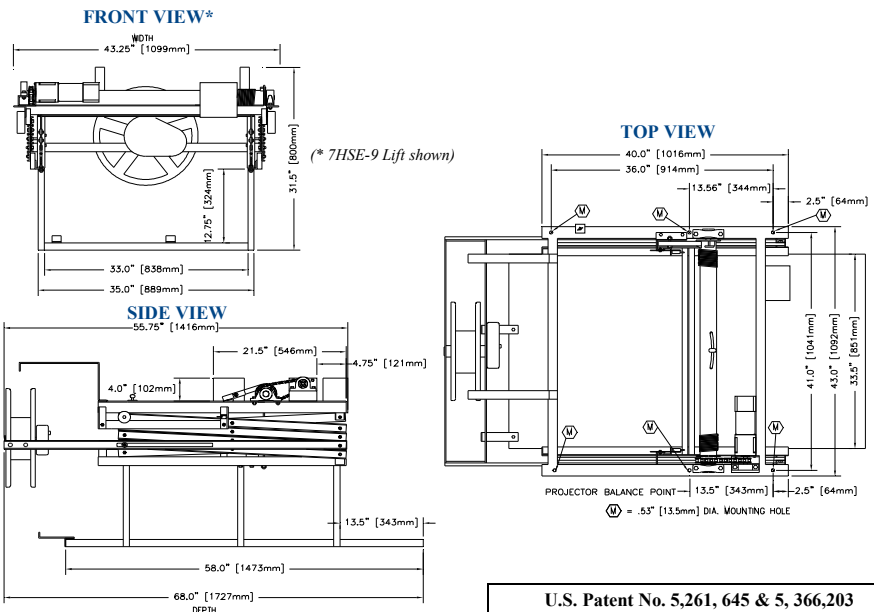

U.S. Patent No. 5,261, 645 & 5, 366,203

Eastern Sales/ Main Office
Tel: 850-522-4747
Fax: 850-522-4739

Western Sales Office
Tel: 720-283-6410
Fax: 720-283-6424

International Sales Office
Tel: 001-720-283-6410
Fax: 001-720-283-6424

www.svslifts.com
sales@svslifts.com