

SVS CEILING LIFTS

For Projectors up to 32.5" Wide

SVS 7EX Series



PRODUCT FEATURES

- Supports projectors up to 32.5" Wide [825.5 mm] -width must include video cable connections if on the side of projector
- Ideal Solution for installations with restricted space (projector installed inside the lift – between scissors- to minimize vertical height)
- Lowering distances from 9'0" to 22'6" [2.7 m to 6.9 m]
- Lifting capacity up to 700 lbs [317.52 kg]
- Three positions: Stored, Show (adjustable) & Service
- Includes 24VAC wall plate controller for low voltage control & standard video cable management system
- Very quiet operation
- Warranty: 5 Year parts, 1 year motor & 90 day factory labor

SPECIFICATIONS

LIFT MODEL	MAXIMUM LOWERING DISTANCE	VERTICAL HEIGHT OF LIFT IN CLOSED POSITION (1) (CEILING CLOSURE NOT INCLUDED)	INSIDE VERTICAL CLEARANCE FOR PROJECTOR AND PROJECTOR MOUNT	PHYSICAL DIMENSIONS		NET WEIGHT	SHIPPING WEIGHT
				WIDTH	DEPTH		
7EX-9	9'0" /2.7m	16" /406mm	10" /254 mm	43.25" /1098mm	45" /1143mm	175 lbs/ 79.3 kg	290 lbs/ 131.5 kg
7EX-11	11'3" /3.4m	17.5" /445mm	11.5" /292 mm	43.25" /1098mm	45" /1143mm	190 lbs/ 86.1 kg	310 lbs/ 140.6 kg
7EX-13	13'6" /4.1m	19" /483mm	13" /330 mm	43.25" /1098mm	45" /1143mm	205 lbs/ 92.9 kg	330 lbs/ 149.6 kg
7EX-15*	15'9" /4.8m	20.5" /521mm	14.5" /368 mm	43.75" /1111mm	47.5" /1207mm	265 lbs/ 120.2 kg	360 lbs/ 163.2 kg
7EX-18*	18'0" /5.5m	22" /559mm	16" /406 mm	43.75" /1111mm	47.5" /1207mm	290 lbs/ 131.5 kg	390 lbs/ 176.9 kg
7EX-20*	20'3" /6.2m	23.5" /597mm	17.5" /444 mm	43.75" /1111mm	47.5" /1207mm	305 lbs/ 138.3 kg	410 lbs/ 185.9 kg
7EX-22*	22'6" /6.9m	25" /635mm	19" /482mm	43.75" /1111mm	47.5" /1207mm	320 lbs/ 145.1 kg	430 lbs/ 195.0 kg

* Accessory #7 Video cable Retractor Included.

(1) Vertical height may vary depending on height of projector. Supporting structure is additional

STANDARD SPECIFICATIONS

Voltage 110v/220V, 60/50hz
Current Draw 1.5 amps [110v], .75 amps [220v]
Control Voltage 24 VAC (contact closure)
Materials Steel/Aluminum/Nylon

RECOMMENDED ACCESSORIES

#1 Ceiling Closure – Self-aligning closure system complete with ceiling framework. Supplied with 15/16" ceiling trim ring. Designed to accept ceiling tile or dry wall ceiling. Supplied unpainted.

FP1 Ceiling Closure -Fixed mounted flat closure panel-Lipped or Lipless. Supplied with 15/16" ceiling trim ring. Ceiling material attaches to the bottom of the panel or closure can be painted. Supplied unpainted.

#2 Plenum Shroud – Protective Metal cover for lift & projector in air plenum rated ceiling.

#9 Mount - Mounting bracket used to attach the projector to the saddle of the lift in an inverted position (model varies with the projector model).

**FRONT VIEW (*)
(7EX-9, 7EX-11, 7EX-13)**

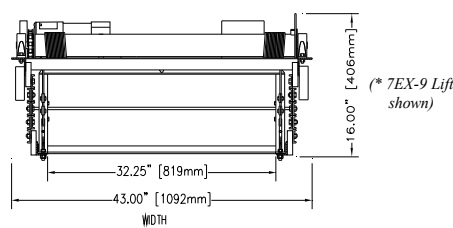

**FRONT VIEW (*)
(7EX-15, 7EX-18, 7EX-20, 7EX-22)**

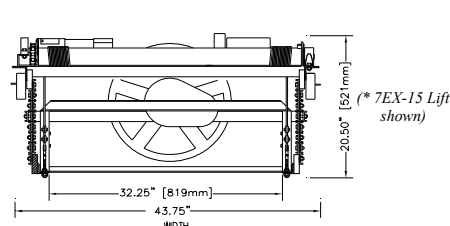

U.S. Patent No. 5,261, 645 & 5, 366,203

**TOP VIEW
(7EX-9, 7EX-11, 7EX-13)**

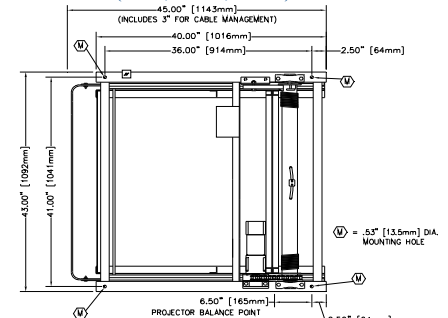

**TOP VIEW
(7EX-15, 7EX-18, 7EX-20, 7EX-22)**

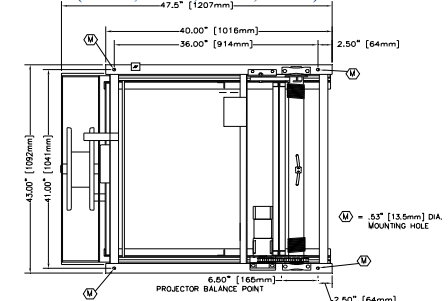

Eastern Sales/ Main Office
 Tel: 850-522-4747
 Fax: 850-522-4739

Western Sales Office
 Tel: 720-283-6410
 Fax: 720-283-6424

International Sales Office
 Tel: 001-720-283-6410
 Fax: 001-720-283-6424

www.svslifts.com
 sales@svslifts.com