

SVS CEILING LIFTS

For large & heavy projectors

SVS 12HSE Series

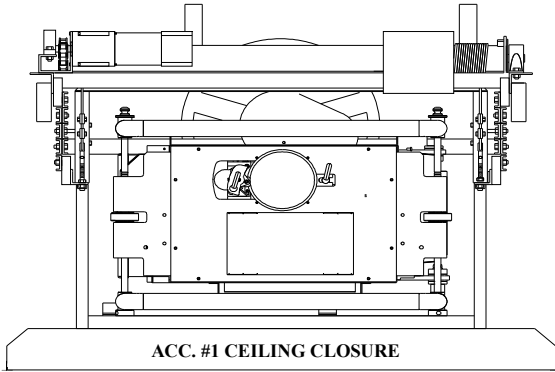

PRODUCT FEATURES

- For "large projectors" requiring additional size and weight accommodations.
- Lowering distances from 24'9" to 33'8" [7.5 m to 10.3 m]
- Lifting capacity up to 900 lbs [408 kg]
- Three positions: Stored, Show (adjustable) & Service
- Supplied with 24VAC wall plate controller for low voltage control, two Accessory #7 video cable retractors & a removable #13 platform (to support the projector in an upright position)
- Very quiet operation
- Warranty: 5 Year parts, 1 year motor & 90 day factory labor

SPECIFICATIONS

LIFT MODEL	MAXIMUM LOWERING DISTANCE	VERTICAL HEIGHT OF LIFT IN CLOSED POSITION	PHYSICAL DIMENSIONS		NET WEIGHT	ESTIMATED SHIPPING WEIGHT
			WIDTH	DEPTH		
12HSE-24	24'9" / 7.6m	Vertical Height Varies with projector	44.25" / 1124mm	65" / 1651mm	410 lbs/ 185.9 kg	520 lbs/ 235.8 kg
12HSE-29	29'3" / 8.9m				450 lbs/ 204.1 kg	530 lbs/ 240.4 kg
12HSE-33	33'8" / 10.3m				470 lbs/ 213.1 kg	610 lbs/ 276.6 kg

(1) Vertical height may vary depending on height of projector. Supporting structure is additional

STANDARD SPECIFICATIONS

Voltage 110v/220V, 60/50hz
Current Draw 1.5 amps [110v], .75 amps [220v]
Control Voltage 24 VAC (contact closure)
Materials Steel/Aluminum/Nylon

RECOMMENDED ACCESSORIES

#1 Ceiling Closure – Self-aligning closure system complete with ceiling framework. Supplied with 15/16" ceiling trim ring. Designed to accept ceiling tile or dry wall ceiling. Supplied unpainted.

FP1 Ceiling Closure -Fixed mounted flat closure panel- Lipped or Lipless. Supplied with 15/16" ceiling trim ring. Ceiling material attaches to the bottom of the panel or closure can be painted. Supplied unpainted.

#2 Plenum Shroud – Protective Metal cover for lift & projector in air plenum rated ceiling.

FRONT VIEW

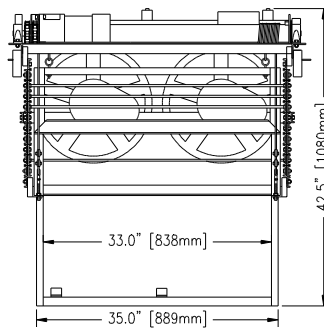

SIDE VIEW

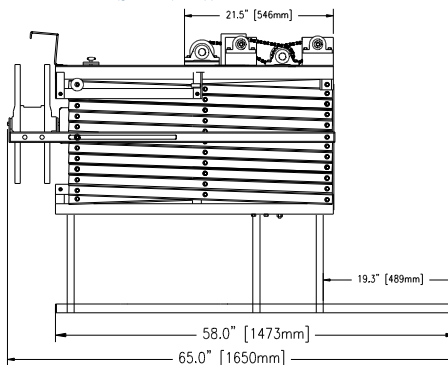

TOP VIEW

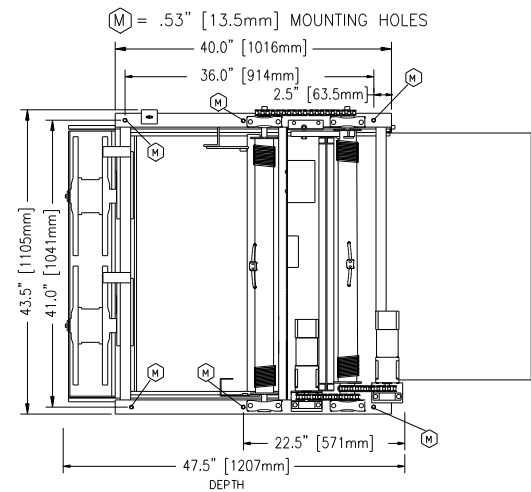

U.S. Patent No. 5,261, 645 & 5, 366,203

Eastern Sales/ Main Office
 Tel: 850-522-4747
 Fax: 850-522-4739

Western Sales Office
 Tel: 720-283-6410
 Fax: 720-283-6424

International Sales Office
 Tel: 001-720-283-6410
 Fax: 001-720-283-6424

www.svslifts.com
 sales@svslifts.com